

High performance computations for short-lived plasmas

Olga Olkhovskaya, Gennadiy Bagdasarov,
Vladimir Gasilov, Yulia Sharova



November 22-23, 2018, Moscow

MARPLE3D

is an expandable full-scale multiphysics research platform using the state-of-the-art physics, mathematics, and numerics as well as the up-to-date high performance computing functionality.

The code MARPLE comprises the computing environment for parallel computations of initial-boundary value problems using unstructured computational meshes and physical solvers developed in this environment.

Reference

V. Gasilov et al. Towards an Application of High-performance Computer Systems to 3D Simulations of High Energy Density Plasmas in Z-Pinches.// In: Applications, Tools and Techniques on the Road to Exascale Computing. IOS Press, "Advances in parallel Computing", 2012, Vol. 22, p. 235-242.

MARPLE3D main physics:

- one-fluid two-temperature MHD model including electron-ion energy relaxation and general Ohm's law (N.A.Bobrova, E.Lazzaro, P.V.Sasorov.

Magnetohydrodynamic two-temperature equations for multicomponent plasma. Phys. Plasmas, 12, 2005, 022105)

- anisotropic resistivity and heat conductivity in the magnetic field
- radiative energy transfer: multigroup spectral model, diffusion model, Sn-method, second-order self-adjoint equation

(B.N. Chetverushkin, O.G. Olkhovskaya, V.A. Gasilov // Doklady Mathematics, 2015, Vol. 92, No. 2, pp. 528–531)

- wide-range equations of state, transport and kinetic coefficients, opacity and emissivity: analytics and/or data tables – code TERMOS (KIAM RAS)

(A. F. Nikiforov, V. G. Novikov, V. B. Uvarov, Birkhauser Verlag, Basel, Berlin, 2005)

- multi-component convection-diffusion, semi-empirical turbulence model

MARPLE3D main numerics:

- mixed unstructured / block meshes; tetrahedral, hexahedral, prismatic elements and their combinations; octree meshes;

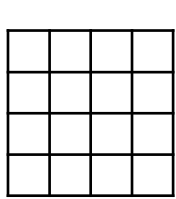

Rectangular
mesh

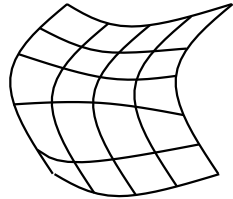

Topologically
rectangular
mesh

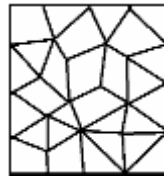

Unstructured
mesh

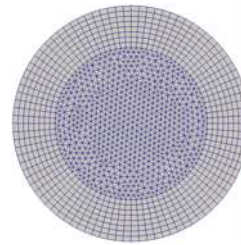

Block mesh

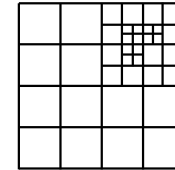

Octree
mesh

- high-resolution TVD/WENO approximations to the ideal MHD equations, implicit FV/FE/DG techniques for dissipative processes;
- splitting scheme for RMHD system with elemental solvers for physical processes of different nature, additive approximation scheme, conservation laws;
- 2-nd order predictor-corrector time-advance scheme.

MARPLE3D governing system:

Non-dissipative MHD

$$\frac{\partial}{\partial t} \rho + \nabla(\rho \vec{w}) = 0,$$

$$\frac{\partial}{\partial t} \rho w_i + \sum_k \frac{\partial}{\partial x_k} \Pi_{ik} = 0,$$

$$\Pi_{ik} = \rho w_i w_k + P \delta_{ik} - \frac{1}{4\pi} \left(B_i B_k - \frac{1}{2} B^2 \delta_{ik} \right),$$

$$\frac{\partial}{\partial t} \vec{B} - \nabla \times (\vec{w} \times \vec{B}) = 0,$$

$$\frac{\partial}{\partial t} \left(\rho \varepsilon + \frac{1}{2} \rho w^2 + \frac{B^2}{8\pi} \right) + \nabla \vec{q} = 0,$$

$$\vec{q} = \left(\rho \varepsilon + \frac{1}{2} \rho w^2 + P \right) \vec{w} + \frac{1}{4\pi} \vec{B} \times (\vec{w} \times \vec{B}),$$

$$P = P(\rho \varepsilon).$$

Dissipative processes

Magnetic field diffusion

$$\vec{E} = \frac{\vec{j}_{\parallel}}{\sigma_{\parallel}} + \frac{\vec{j}_{\perp}}{\sigma_{\perp}},$$

$$\text{rot } \vec{B} = \frac{4\pi}{c} \vec{j} = \frac{4\pi}{c} \hat{\sigma} \vec{E},$$

$$\frac{1}{c} \frac{\partial \vec{B}}{\partial t} = -\text{rot } \vec{E}$$

Heat conductivity, electron-ion relaxation,
Joul heating, radiative cooling

$$\frac{\partial(\rho \varepsilon_e)}{\partial t} = -\text{div}(\hat{\kappa}_e \text{grad } T_e) + Q_{ei} + G_J + G_R$$

$$\frac{\partial(\rho \varepsilon_i)}{\partial t} = -\text{div}(\hat{\kappa}_i \text{grad } T_i) - Q_{ei}$$

$$\varepsilon = \varepsilon_i + \varepsilon_e, \quad P = P_i + P_e$$

MARPLE3D main software development concepts:

- the code is designed for high performance distributed computations,
- computing environment incorporates a set of service functions (data IO, mesh processing, parallel computations support, dynamic processing of computation objects),
- dynamic creating, deleting, and setting up different types of objects, automatic memory management; no need to change or disable existing objects when adding new ones, unified all-mode code build with no runtime storage and computer power surplus costs;
- physical solvers hierarchy; handling of several physical subregions, each with unique governing system; add-on of new physical or mathematical models is possible,
- configurable recovery points writing and automated backup, advanced events logging,
- object-oriented design, object-oriented and general programming techniques (C++ based), state-of-the-art development tools and approaches;
- cross-platform development (including CMake crossplatform build tool).

MARPLE3D third-party components (open source):

- ▶ METIS / ParMETIS – serial / parallel programs for partitioning unstructured meshes

<http://glaros.dtc.umn.edu/gkhome/views/metis>



- ▶ Aztec / Trilinos – a library for the iterative solution of large sparse linear systems

<http://www.cs.sandia.gov/CRF/aztec1.html>, <https://trilinos.org/>



- ▶ ZLib / zipstream / gzstream - a library and C++ wrappers for data compression

<http://www.zlib.net/>,
<http://www.cs.unc.edu/Research/compgeom/gzstream/>



- ▶ ParaView – data analysis and visualization application

<http://www.paraview.org/>



- ▶ SALOME – CAD-CAE platform for preparation of complex geometry computational domains for the numerical simulation, including geometry description, boundary and subregions attributes settings, mesh generation and refinement

<http://www.salome-platform.org/>



The use of open software:

- facilitates the development and debugging of the codes, as well as training new users, including students;
- helps to provide the portability and standardization of the created codes;
- allows coupling our codes with the codes of other developers.

MARPLE3D is distributed freely

in the framework of scientific cooperation:

- theoretical and numerical support of experiments on high-current generators (ANGARA-5-1 in TRINITI, Troitsk, S-300 and Calamary in NRC "Kurchatov Institute", Moscow) and laser installations (ELI Beamline, Prague, Czech Republic)
- astrophysical modeling (Laboratoire d'Annecy-le-Vieux de Physique Theorique, Annecy, France).

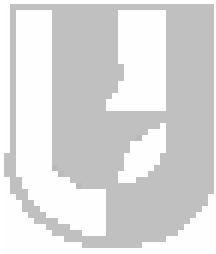

DENSE Z-PINCHES STUDIES

Experiments: Troitsk Institute for Innovation and Fusion Research
(TRINITI), Troitsk, Moscow reg.
ANGARA 5-1 FACILITY

CURRENT PULSE: 4 MA, 600 KJ, 90 ns

X-ray PULSE: ENERGY 30-100 kJ, DURATION 6-10 ns

LOAD: WIRE ARRAYS (Al, W, Mo, Cu), 40 - 200 wires, $\varnothing 4 - 10$ mkm

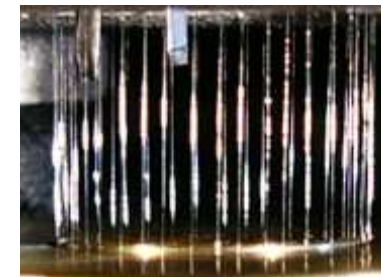

h=15mm

Ø20mm

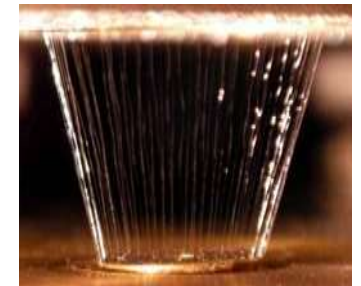

h=15mm



Ø12mm

DENSE Z-PINCHES STUDIES

Experimental setups

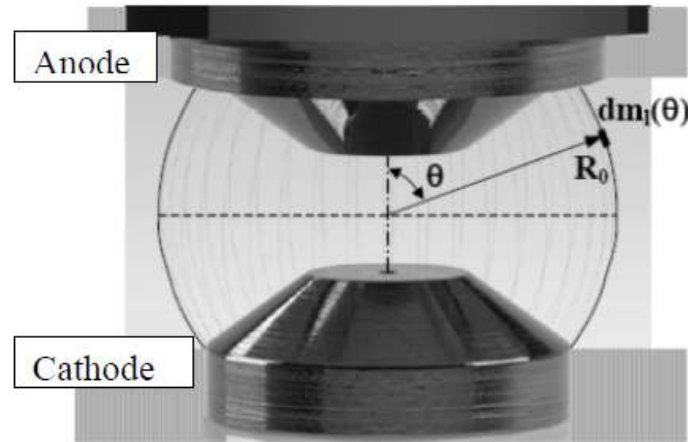
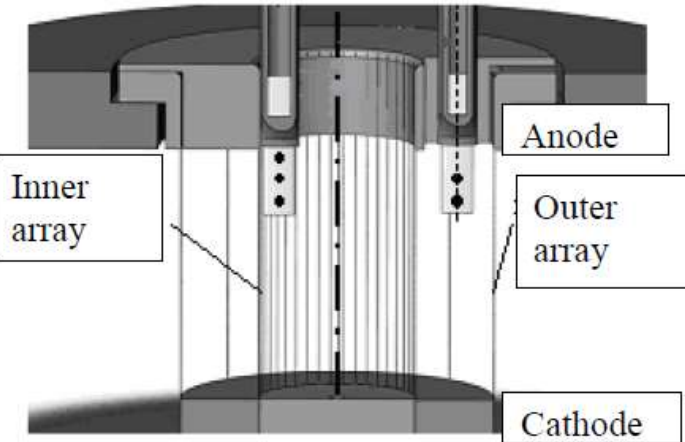

Experimental laser shadow image: a shock wave between wire arrays

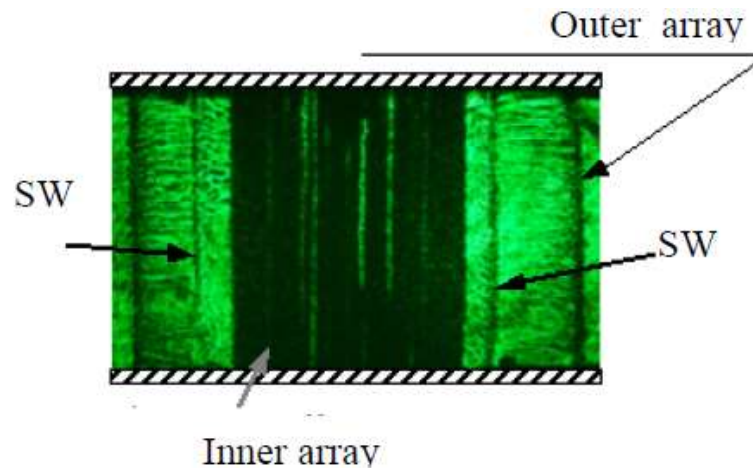

Computational domains and meshes

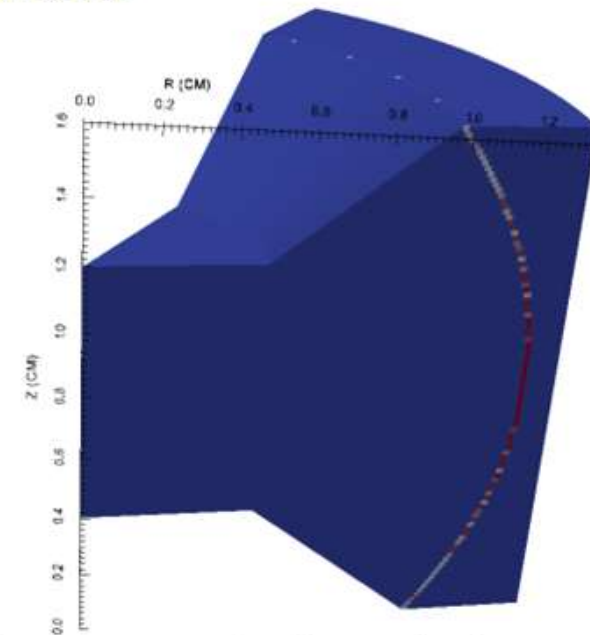
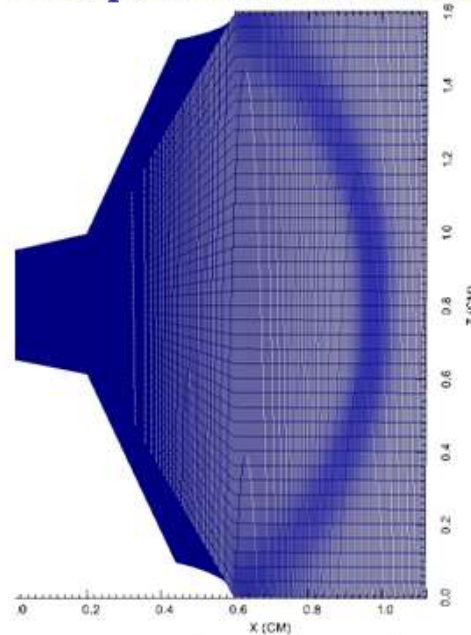

Computational domain: cylindrical sector 60° with periodic boundary conditions.
Computational mesh: $2 \div 4$ M ($h_\phi \approx 50 \div 10 \mu\text{m}$, $h_r \approx 50 \div 10 \mu\text{m}$, $h_z = 160 \div 40 \mu\text{m}$).
One version calculating time on 256 cores is about 30-40 hours.

DENSE Z-PINCHES STUDIES

3D simulation results: cylindrical nested array

quasispherical nested array

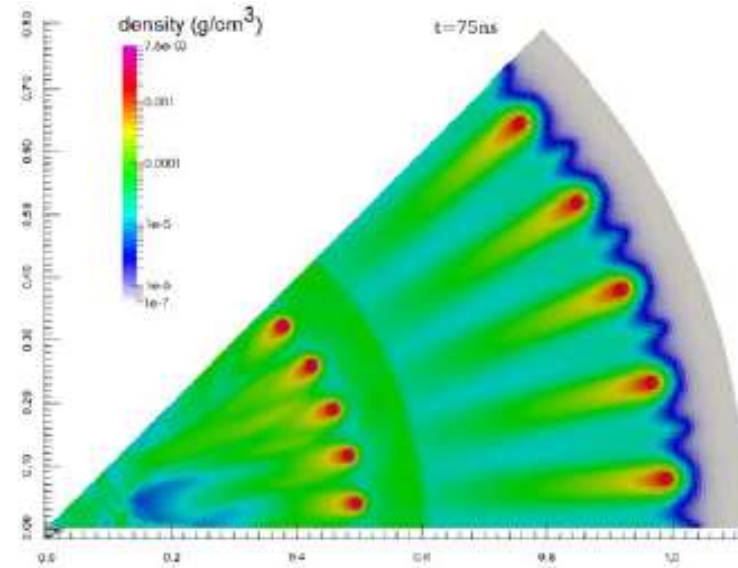
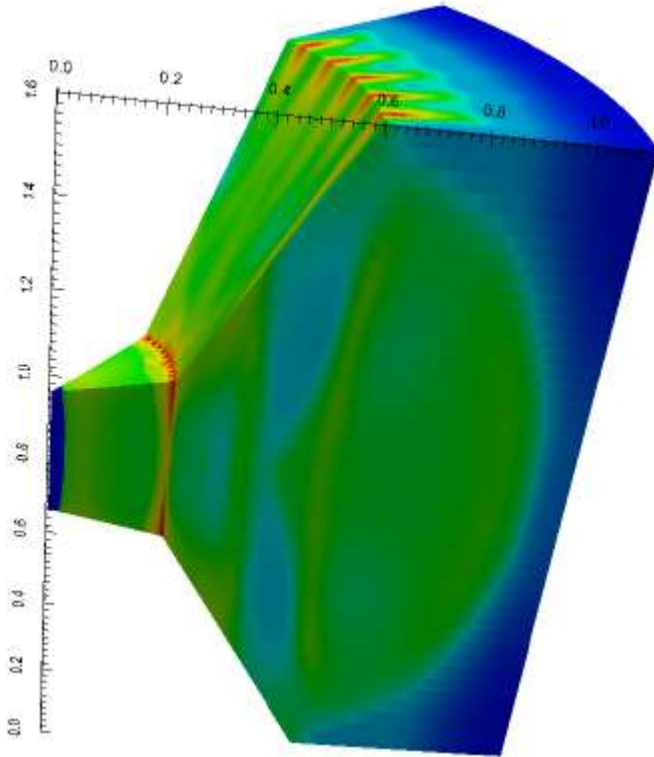

Dependence of the compression mode on the ratio of the rates of plasma production and the ratio of the arrays radii.

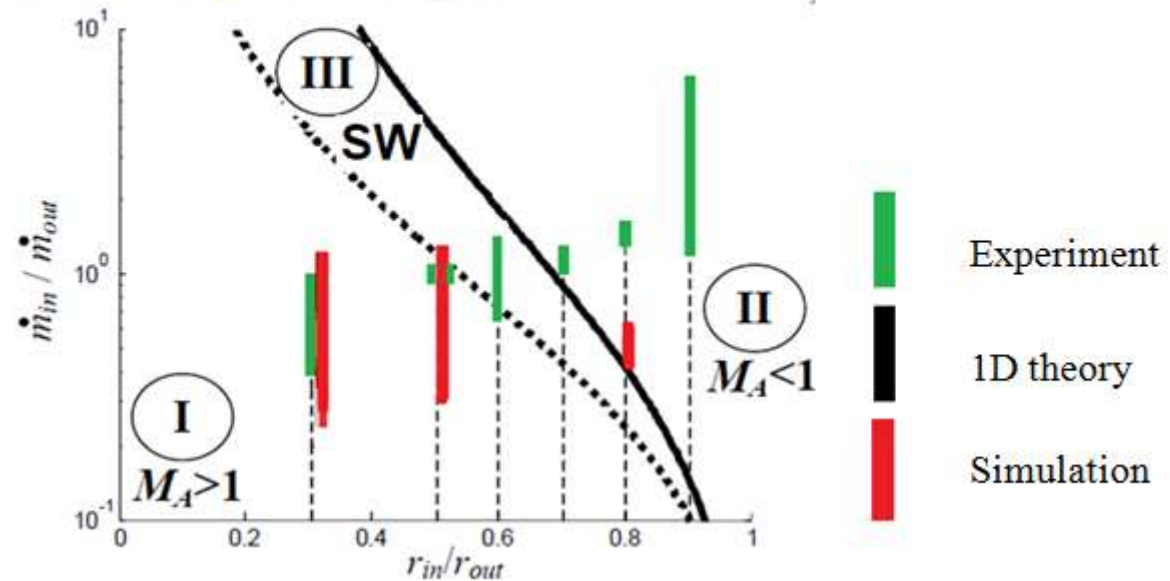

High performance computations for short-lived plasmas

Olga Olkhovskaya, Gennadiy Bagdasarov,
Vladimir Gasilov, Yulia Sharova



The research is carried out using the equipment of the shared research facilities of HPC computing resources at Lomonosov Moscow State University, and at Joint Supercomputer Center of the Russian Academy of Sciences (JSCC RAS).

November 22-23, 2018, Moscow