

Кайдзен или 5 шагов на пути к гибкости

Таисия Рыбак
Директор по развитию ALM
По Центральной и Восточной Европе
Hewlett-Packard



Что говорит Gartner

Количество релизов в год будет расти

Что ожидается:

- ПО везде
- Доступ через различные девайсы
- 30ти кратное увеличение частоты релизов
- Сокращение ресурсов

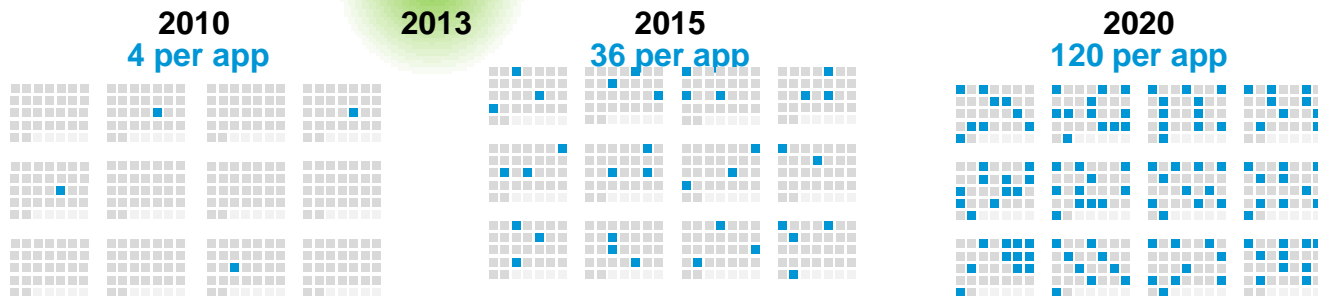

Процессы



За процессом нужно следить



Шаг 1 – Управляй процессом

HP Agile Manager



Разработка HP



> 250 продуктов

- Интернациональная команда
- Интеграции
- Мощные продукты
- Долгосрочные инициативы

Планирование

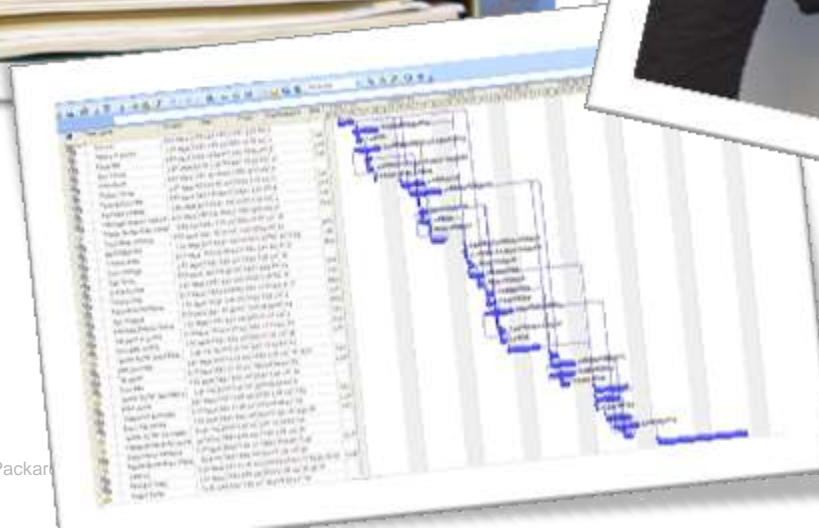



Планирование: Release backlog



Home Product Backlog **Release Management** Defect Management Dev Insight Recent Items

AGM V1.0 Release Backlog Planning Board Sprint Backlog Taskboard Sprint Closure

Release Backlog

Defect Status: 1-Low, 2-Medium, 3-High, 4-Very High, 5-Urgent. Legend: Done, New, In Progress, In Testing.

Story Summary: Done (541), In Progress (24), New (225), In Testing (1).

Clear Filters + Add Item - X Delete -> Planning - More Actions - Refresh * Favorites -

Block	Add New User Story	Add New Defect	Rank	Assigned To	Story Points	Status	Sprint	Team
				Nurit Guthrie	1	New	Sprint 22.2	Platform App Service
				Tomer Avni	1	New	Sprint 22.2	Shmuel Team
				Nir Yam Tov	1	New	Sprint 22.2	Shmuel Team
				Martin Panacek		New		Petr Ali Team
			11	Tsila Cochevi	2	New	Sprint 22.1	UX & Graphics
					6	New		Platform Self Service
					1	New		Platform Self Service
					1	New		Platform Self Service
			210		2	New		Shmuel Team
				Ronen Shmuel	1	New	Sprint 22.2	Shmuel Team
						New		

799 User Stories, 159 Defects | 2137 Story Points | 17% Not Estimated | 515 Items have no tasks

Planning: Sprints & Teams

Sprint 22.2
2012-09-12 - 2012-09-25 (Current)
11/11 Teams
252/284 Story Pts Assigned (89%)

Yisrael Team
5/33 Story Pts Assigned (15%)

Platform Self Service
13/33 Story Pts Assigned (39%)

Platform App Services

Планирование: Sprint backlog

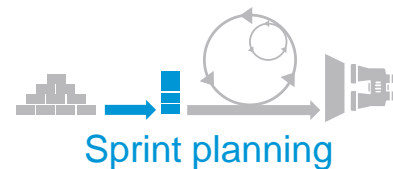

hp Agile Manager

Home Product Backlog **Release Management** Defect Management Dev Insight

My Online Media Store V1.0 Release Backlog **Sprint Backlog** Task Board Sprint Closure

Sprint 5 Orange

Sprint Progress: Working days left: 0 22/10 0/10

Task Summary: Completed: 0 In Progress: 5 New: 14

Story Summary: Done: 1 In Progress: 7 New: 11

+ Add Item Delete Planning More Actions Clear Filters Refresh Favorites Show: Assigned To: All

Blocked	Type	Name	Assigned To	Story Points	Status	Total effort	Invested	Remaining
		Slow performance when scrolling on a large list of items	Alex Losovsky	4	In Progress	23	10	13
		Unable to delete a credit card on file	Robert Plant	13	New	6	0	6
		Long login time on IE8 - 23 seconds	James Horner	12	New	6	0	6
		Problem with persistency - last filtered items are not displayed when retur...	Tom Gibbons	10	New	6	0	6
		Activation E-mail sent to Yahoo e-mail address marked as spam	Peter Wayne	9	In Progress	6	0	6
		As a user, I can search for an album by entering the artist's last name	Alex Losovsky	5	In Progress	42	29	13
		As a user, I can select an album and add it to the shopping cart		7	In Progress	9	4	5
		As a site administrator, I can enter a new movie in the movie store database		11	New			
		As a user, I can select to download the purchased music directly to my iPho...	Alex Losovsky	9	In Progress	36	14	22
		The user's password must adhere to my Online Media Store.com password...		14	New			
		As a user, I can select whether the credit card info will be stored in my acco...		6	In Progress			

Planning: Members

- Alex Losovsky: 64/60 Hrs Assigned (106%)
- Alice Miller: 59/60 Hrs Assigned (98%)
- Cecil Dunn: 33/60 Hrs Assigned (55%)



Канбан доска



hp Agile Manager ora_dec_04 last-name | Configuration | Help | Sign Out

Home | Product Backlog | **Release Management** | Defect Management | Builds | Source Code

Release: Online Media Store V1.0

Release Backlog | **Planning Board** | Sprint Backlog | Task Board | Sprint Closure | All Summary

OOTB Predefined Views

View: **Release backlog life cycle by theme** | Columns: Status | Rows: Team | Colors: Theme | Refresh

Themes: Billing | Book Store | Movie Store | Music Store | Self Provisioning | n/a

	New	In Progress	In Testing	Done
Blue	0	0	75	224
Orange	0	12	55	160

Zoom In/Out



Таскборд

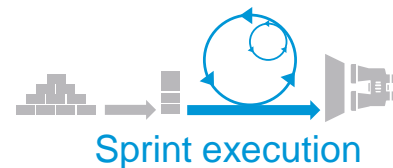

bruce_parker

Configuration

Help

Sign Out

Recent Items

Home

Product Backlog

Release Management

Defect Management

Dev Insight

My Online Media Store V1.0

Release Backlog

Sprint Backlog

Task Board

Sprint Closure

Sprint 5 < > Orange

Search backlog items

Sprint Progress:

Working days left: 1

22/09 06/10

Task Summary



Completed: 4
In Progress: 6
New: 14

Story Summary



In Progress: 7
New: 11

+ Add Item

Refresh

Show: User Stories Defects

Assigned To: <All>

Hide Done Backlog Items

Backlog Item

New - 13 day(s) 1 hour(s)

In Progress - 6 day(s) 3 hour(s)

Completed

User Story | ID 321

As a user, I can search for an album by entering the artist's last name

Status:

In Progress

Testing

4 hours remaining

Alex Losovsky

Write Spec

Alex Losovsky

Coding

Alex Losovsky

UI Mockup

Cecil Dunn

User Story | ID 327

As a user, I can select an album and add it to the shopping cart

Status:

In Progress

Testing

2 hours remaining

Alice Miller

Coding

Cecil Dunn

Design

Cecil Dunn

Статус релиза

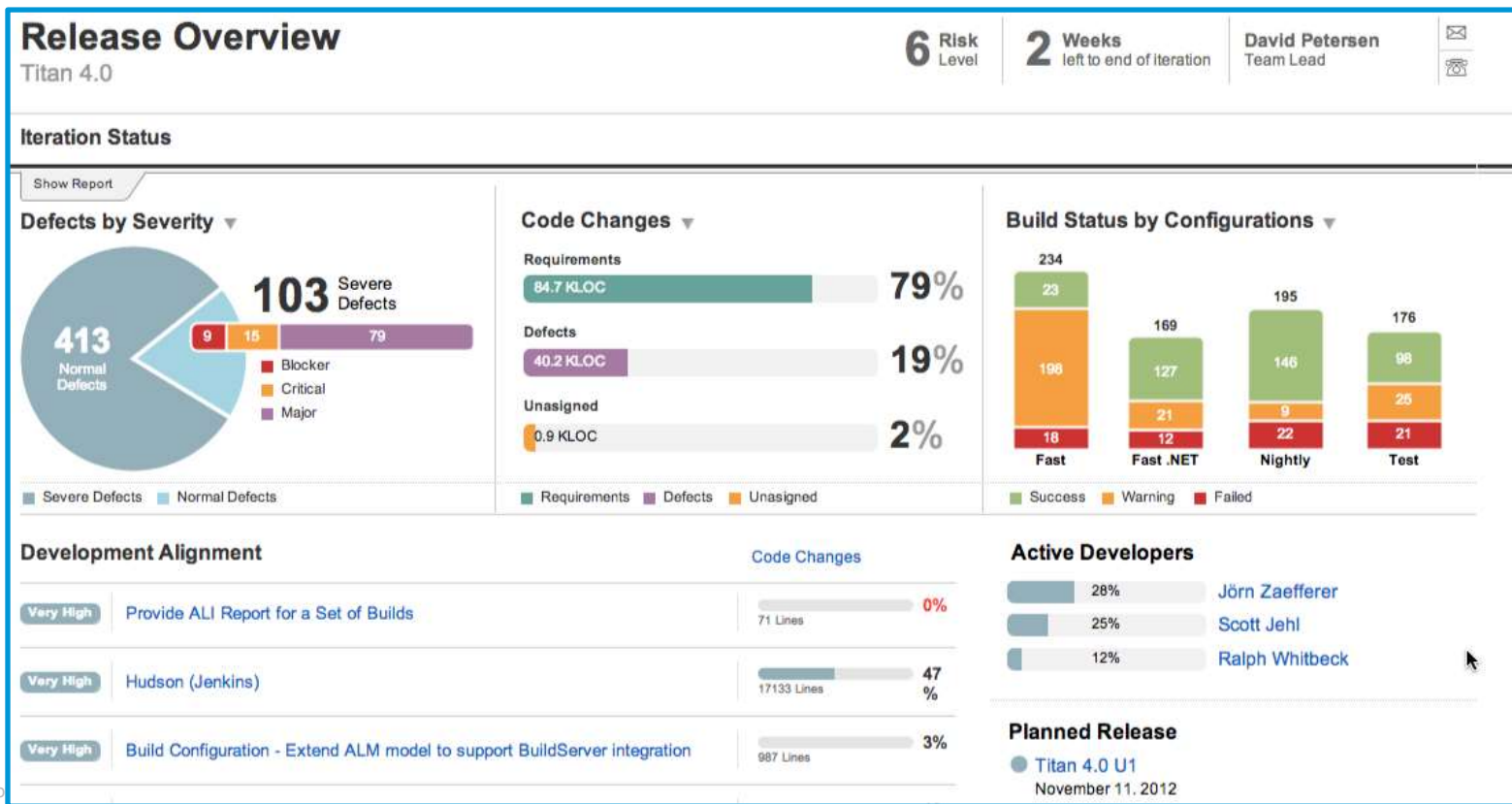

Статус релиза



Release Overview

Titan 4.0

6 Risk Level

2 Weeks left to end of iteration

David Petersen
Team Lead



Iteration Status



Build Success Rate: 73.8% (149 Builds, 39 Failed) | Average Build Time: 36.1 min (69.3 min longest) | Average Time to fix failure: 13.1 h



Сборка



Insight & visibility

Build Summary

Titan 4.0

73% Success Rate
149 Builds, 39 Failed

36min Avg. Build Time
69.3 min longest

Nightly Builds ▾

Time Period: Current Iteration ▾ (Iteration 5)

Show Failed Builds

Latest labeled build: Build Nr. 740 (Iteration 6)

May 1 May 8 May 14 Apr 21 Today

Success Warning Failed

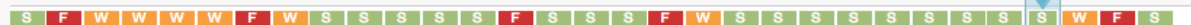

Code Changes ▾

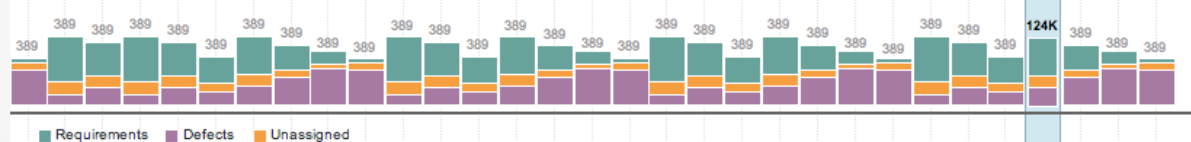

Defects by Severity ▾

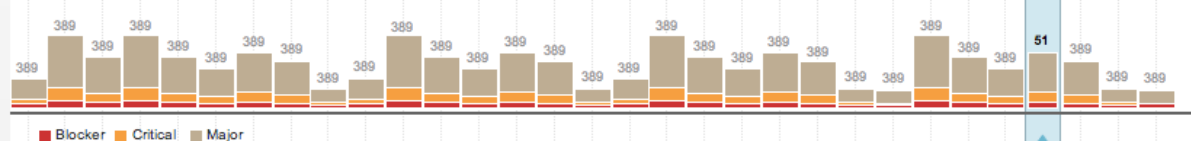

Build Nr. 688

May 21, 2012, 23:38:65 CET

Success Build time: 39 min

Code Changes ▾

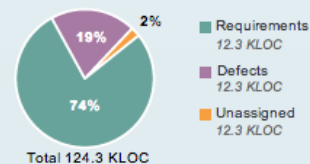

Defects by Severity ▾

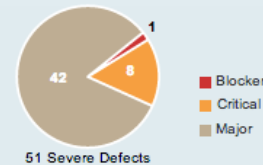

[View Report](#) | [Build System Detail](#)



Статус сборки



Build Summary			73% Success Rate 149 Builds, 39 Failed		36min Avg. Build Time 69.3 min longest	
Titan 4.0						
Nightly Builds ▾			Time Period: Current Iteration ▾ (Iteration 5)		<input checked="" type="checkbox"/> Show Failed Builds	
			Latest labeled build: Build Nr. 740 (Iteration 6)			
Show Report			Development Metrics		Code Changes	
Build Status	Build / Date ▾	Label / Test Status	Unit Tests	Coverage	Lines / Files	Defects Requirements Unassociated
W Warning	Nr. 149 Nov 14, 2011 23:11:53 CET	Not Tested	97%	32%	1440 Lines 58 Files	
F Failed	Nr. 148 Nov 13, 2011 23:11:53 CET	Not Tested	NA	NA	0 Lines 0 Files	NA
F Failed	Nr. 147 Nov 12, 2011 23:11:53 CET	Not Tested	NA	NA	0 Lines 0 Files	NA
F Failed	Nr. 146 Nov 11, 2011 23:11:53 CET	Not Tested	NA	NA	457 Lines 26 Files	
W Warning	Nr. 145 Nov 10, 2011 23:11:53 CET	Demo Server Not Tested	98%	61%	1796 Lines 41 Files	



Настраиваемые отчеты



Insight & visibility Agile Dashboard

Horizon

ALM | Agile Project Management | Milestone 6

Product Backlog | Release Backlog | **Sprint Backlog** | Administration

Planning | Taskboard | Retrospective | **Dashboard**

Aseo, Ronen | APM_CENTER (ALMA) | Help | Sign Out

Recent Items

Sprint 17.2 | Yisrael Team

Sprint dashboard

+ Add Widgets | Change Layout | Refresh

★ Favorites: | Sprint Dashboard

Sprint Burn Down

Sprint Dates Team: Yisrael Team, Sprint: Sprint 17.2

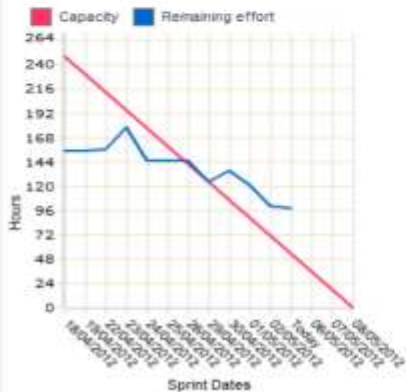

Team Sprint Backlog Lifecycle

Sprint Dates Team: Yisrael Team, Sprint: Sprint 17.2

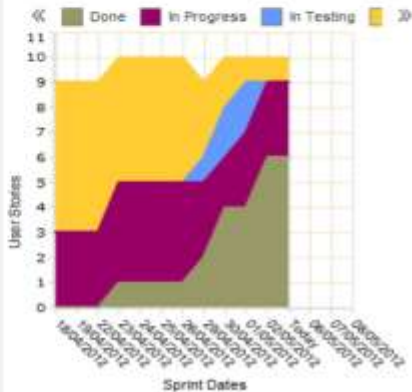

Status Report for Features

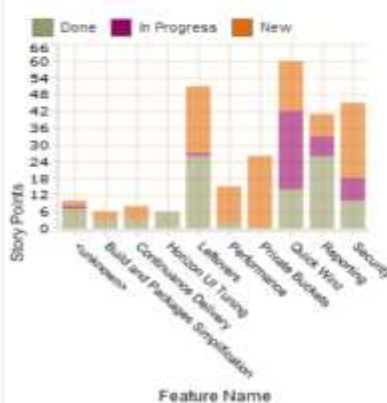

Team Velocity

Sprint Number Team: Yisrael Team, Release: Milestone 6

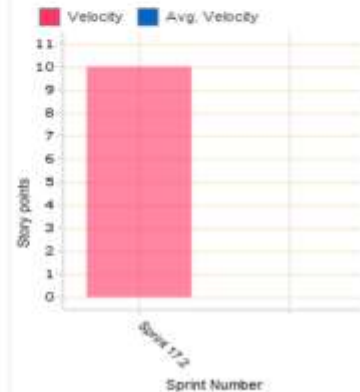

hp.com/go/agilemanager



Шаг 2 – Тестируй раньше

HP Service Virtualization



Ускорьте Agile релизы с помощью виртуализации

Без пауз Ранние исправления

Качественные релизы

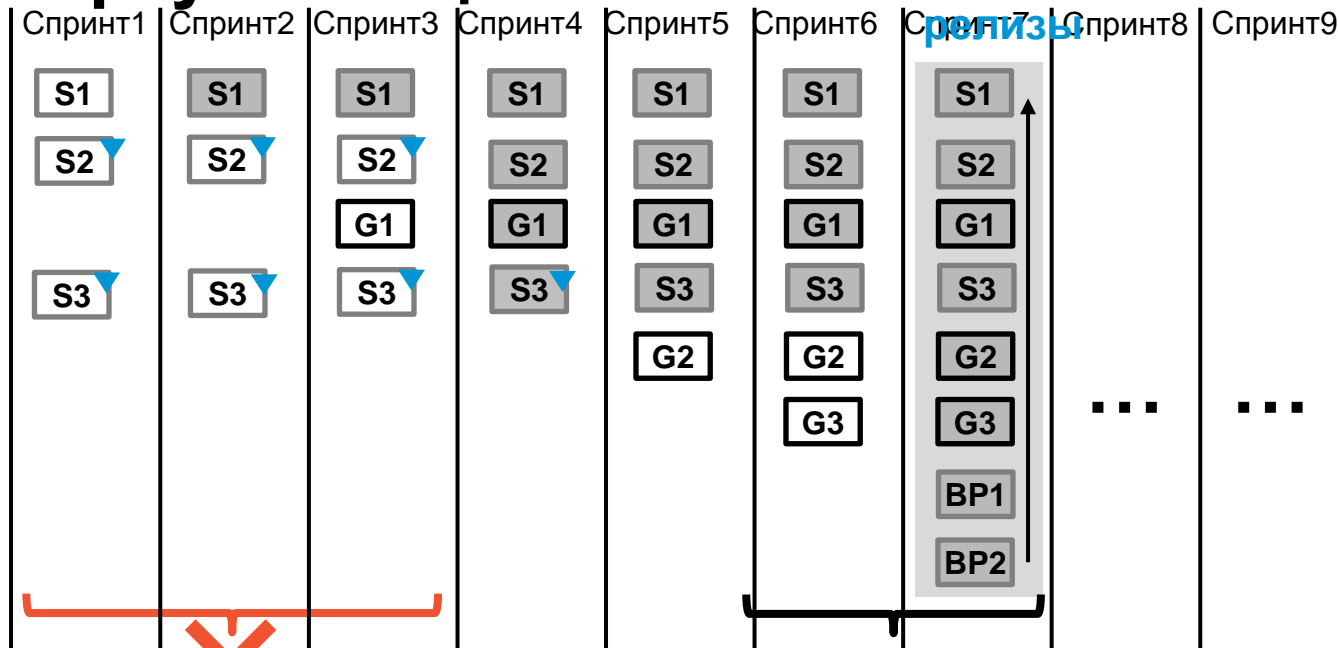

- ▼ Виртуальный сервис
- S Разработанный сервис
- G GUI
- BP Бизнес-процесс
- Стабильные компоненты

Виртуализируйте и предоставляйте нужную компоненту, когда требуется



Среда тестирования мобильных приложений

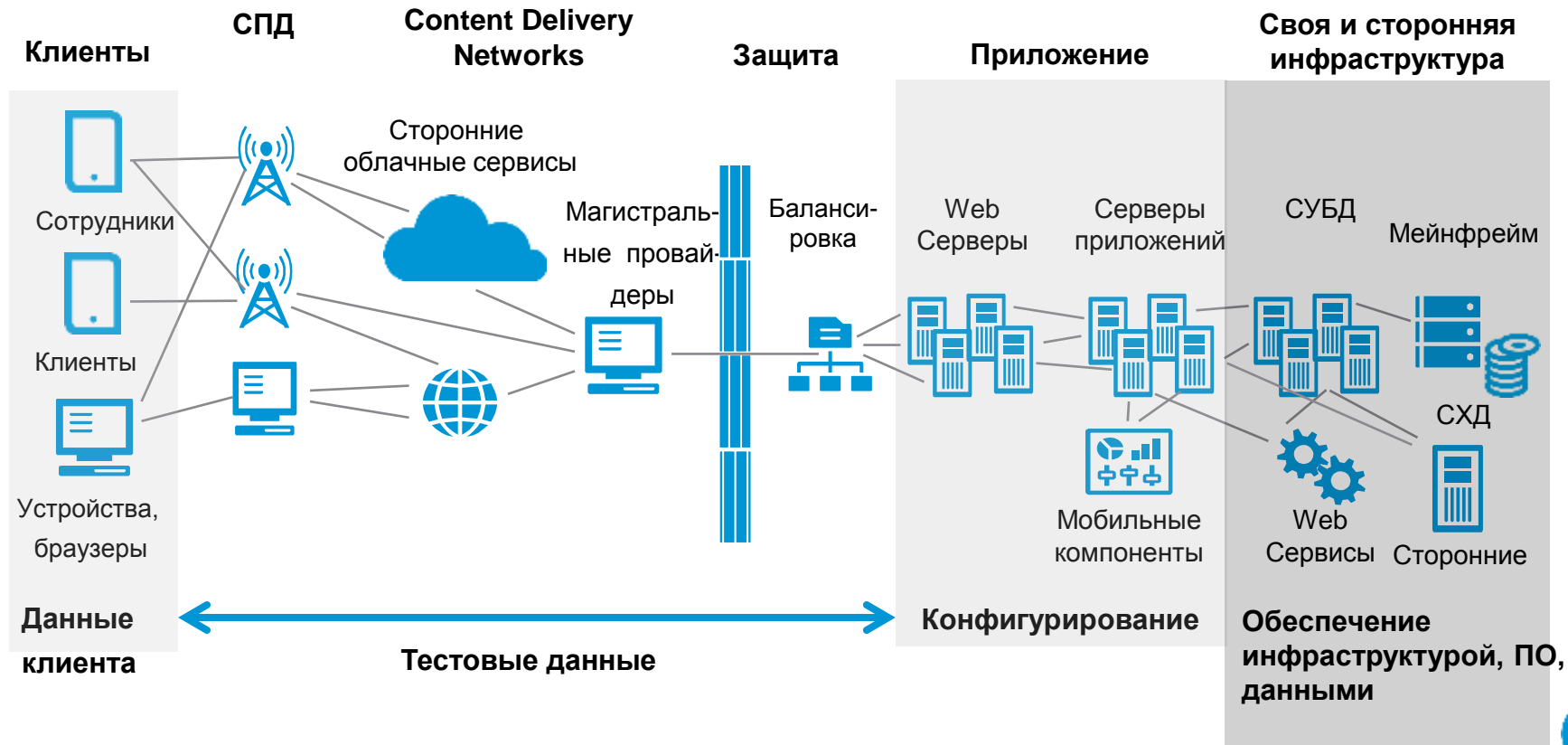

Виртуальные тестовые данные и инфраструктура

- Быстрое развёртывание тестовой среды
- Динамическое изменение данных
- Мгновенный сброс
- Соответствие тестовых данных и бэкенда

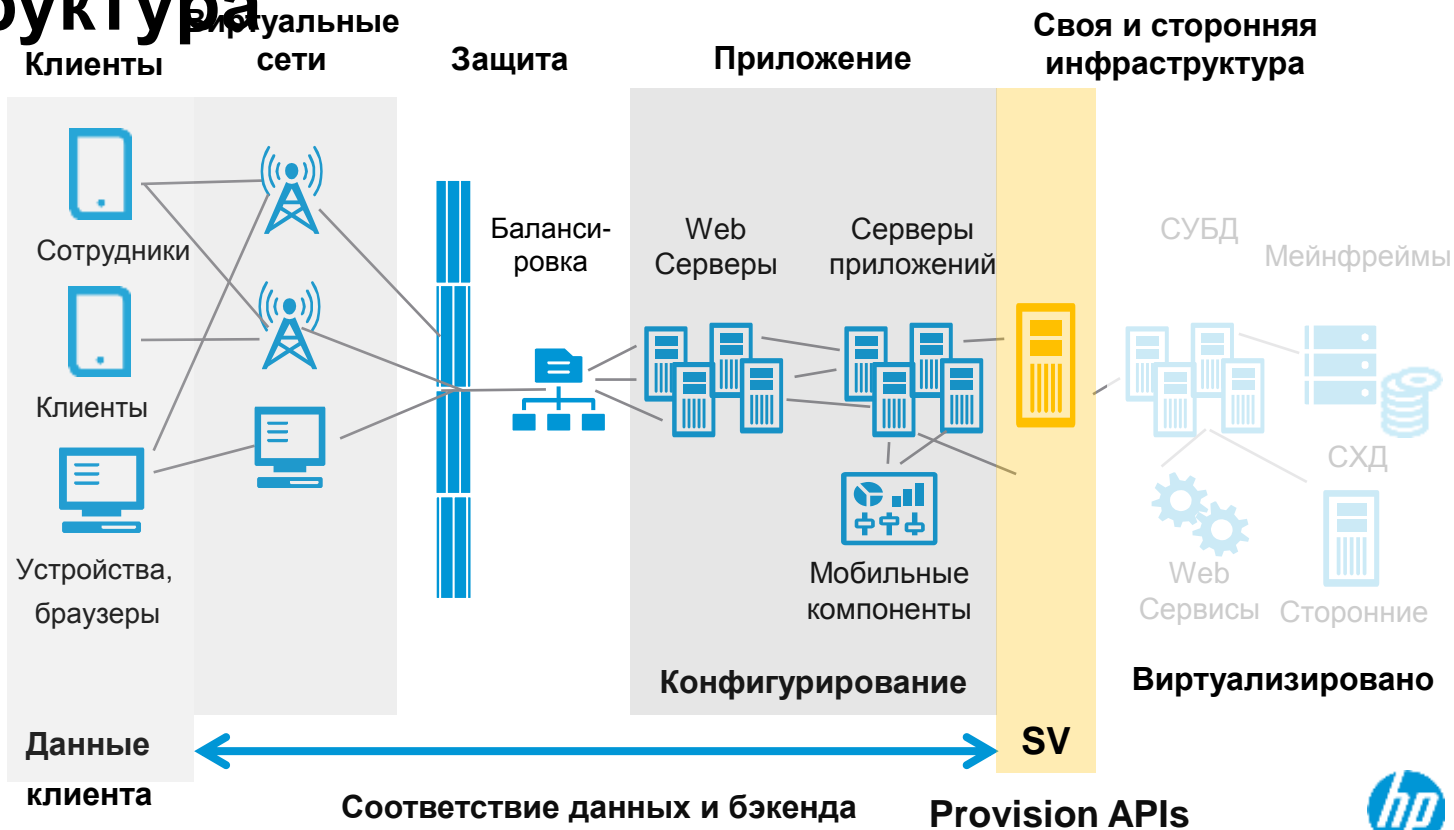

Из чего состоит HP Service Virtualization 3.0

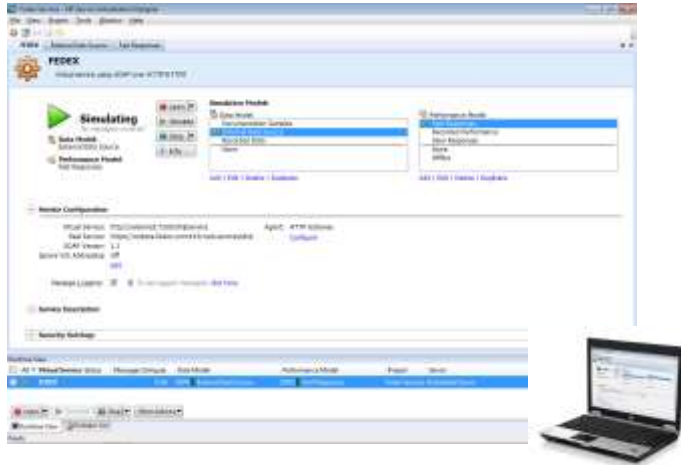

SV Дизайнер

IDE, интеграция с ALM/QC
Моделирование и конфигурирование
виртуальных сервисов
SV Runtime

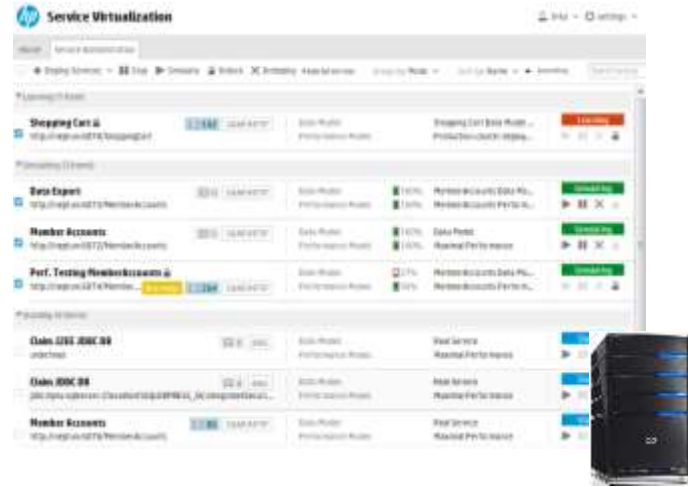

SV Сервер

Разделяемый и масштабируемый
SV Runtime
Интерфейс управления через Web
Доступен через API
Интеграция с репозиторием
ALM/QC



Сайзинг

Параметр	Значение
Структура сообщения	30 элементов (в среднем)
Число сервисов	200
Конкурентные клиенты	48
Размер модели сервиса	1000 уникальных сообщений
Протокол	HTTP / SOAP



Intel Xeon
X5660
2x6 CPU Cores
32 GB Memory

Сервер



Производительность
HP SV

Сервер HP SV обеспечивает **2900**
TPS или **10,440,000** TPH

Результат



Шаг 3 – Тестируй быстрее

HP Unified Functional Testing и тестирование
Мобильных устройств



Универсальность и удобство использования



**Автоматизированное
тестирование UI и Сервисов**



**Шаги ручные и
автоматизированные в одном
фреймворке**



**Тестирование на основе
распознавания объектов и
образов**





Как получить ★★★★★?

Специфичные требования
мобильных решений



1 × 130 × 4 × 20 × 1,5h

Прило-
жение

Тест-
кейсов

Релиза
в год

Поддержи-
ваемых
устройств

На
ручной
прогон
теста

=

15 600

Часов ручного
тестирования
На приложение
В год



HP UFT MOBILE

HP UFT plug-in

Нативная интеграция с HP
ALM

Реальные
устройства



Любые типы устройств

OCR (распознавание
образов и изображений)

Поддержка CI

Управление профилями

Профили, полномочия,
журналирование

Корпоративное решение

Конкурентные прогоны

Безопасность

Полный аудиторский след
Возможность стирания
Удалённый доступ

Глобальность

Доступ повсюду

Нативные функции

GPS, Голосовое
управление,...



Архитектура. 2 режима работы



UFT Mobile

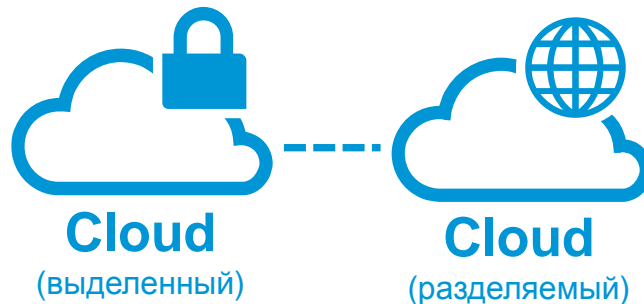

On-premise

HP Mobile

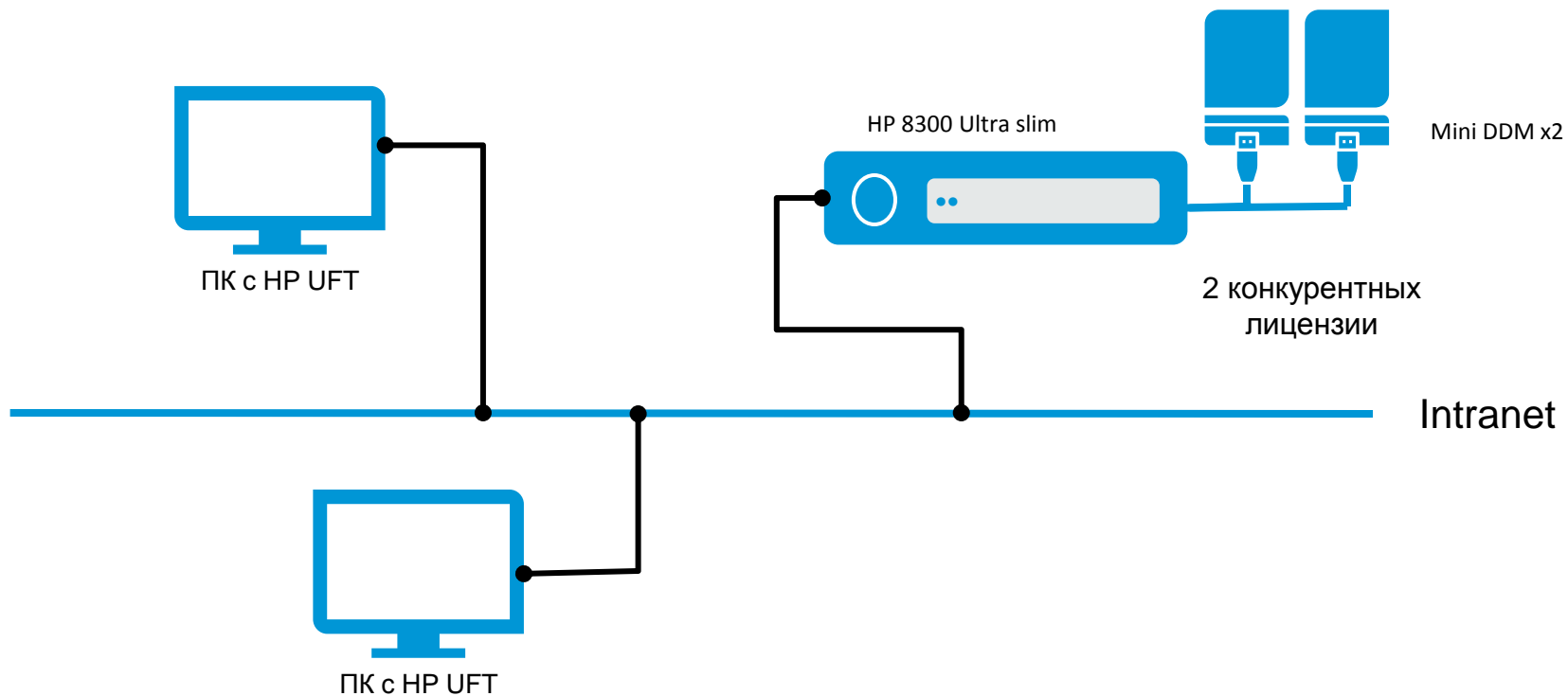

HP Mobile



Внешний вид Mobile Cloud Express



Mini DDM (сзади)



Mini DDM (Спереди)

Шаг 4 – Документирование исследовательского тестирования

HP Sprinter



HP Sprinter

“Как я это сделал?”

- Позвольте записать ваши шаги
- Фокусируйтесь на самой системе
- Запись видео
- Автоматическое создание теста
- Зеркалирование



Автозаполнение



Встроенный графический редактор

“Система умный дефект”

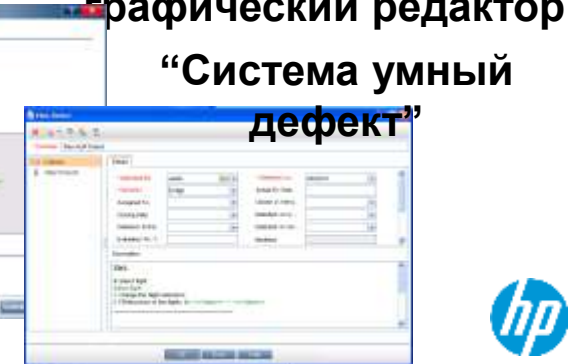

Шаг 5 – Совершенствуйся непрерывно

Нагрузочное тестирование



Что мы можем



Тестирование из облака

Максимальная нагрузка и масштабируемость



Тестирование мобильных приложений

Реалистичное нагрузочное тестирование мобильных устройств



Непрерывное тестирование

DevOps



Комьюнити

Сообщество пользователей и партнеров с готовыми библиотеками

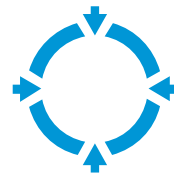

Бесплатный стартовый функционал

Поддержка работы более 60 протоколов от Мэйнфреймов до мобильных устройств

Компоненты нагрузочного тестирования HP

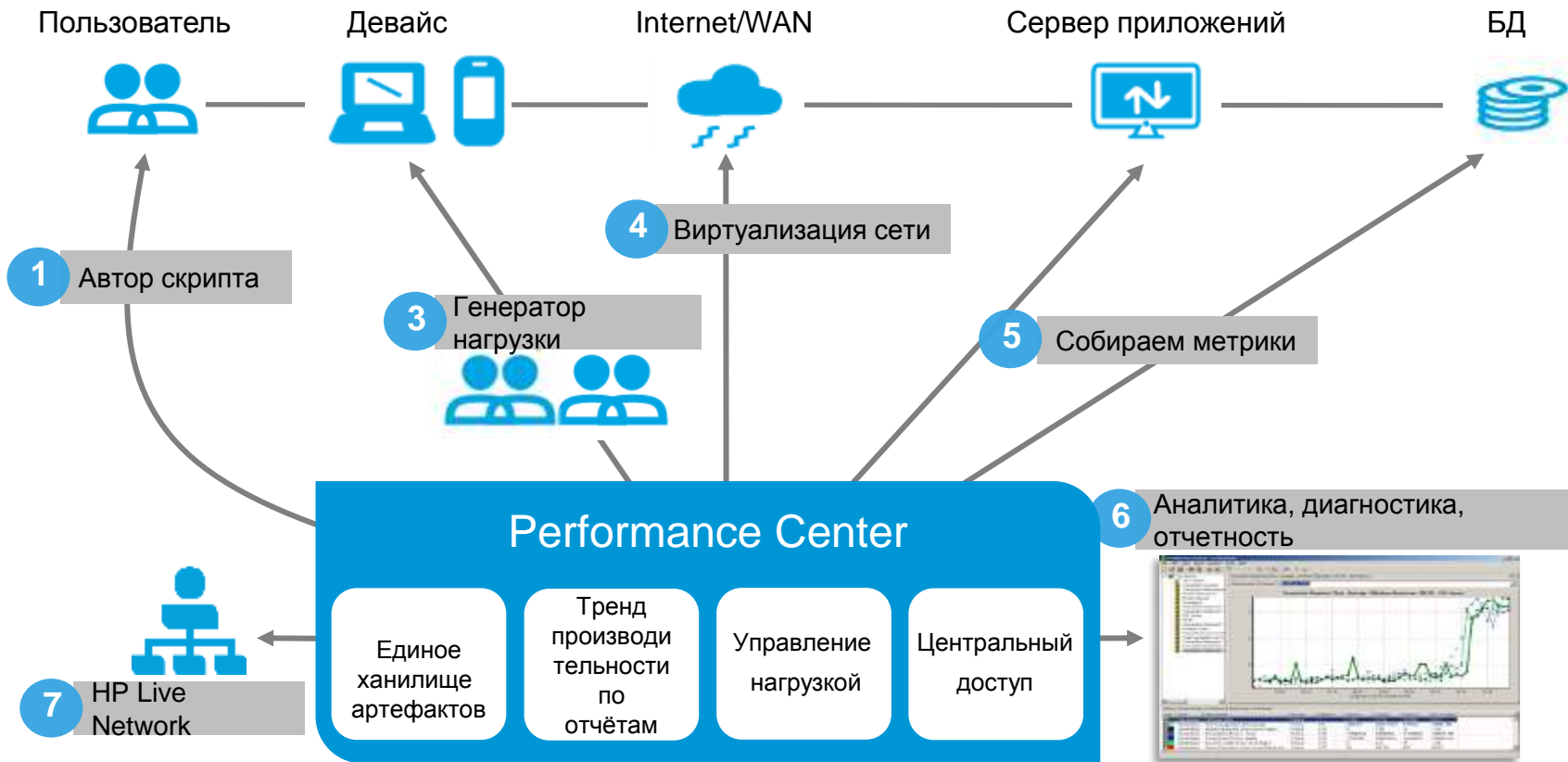

Спасибо.

taisiya.rybak@hp.com

